

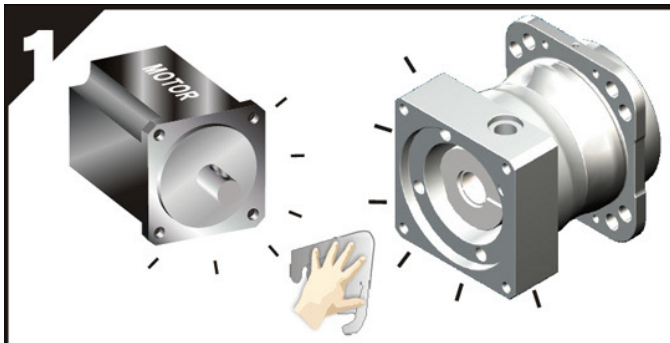

Motor mounting instruction MGO series

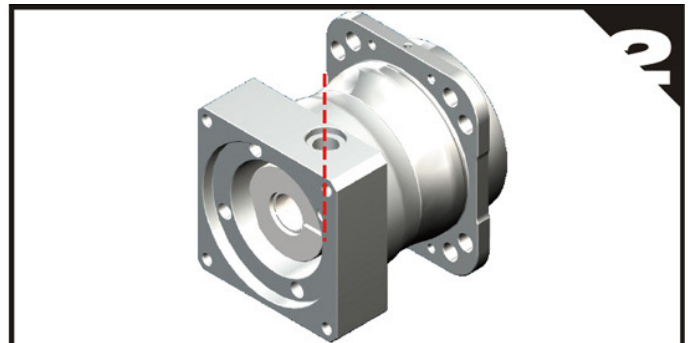

1 Double-check the motor and gearbox size.
Clean the mounting surface



2 Remove the plug on the adapter plate.
Rotate the set collar till the bolt lines up.

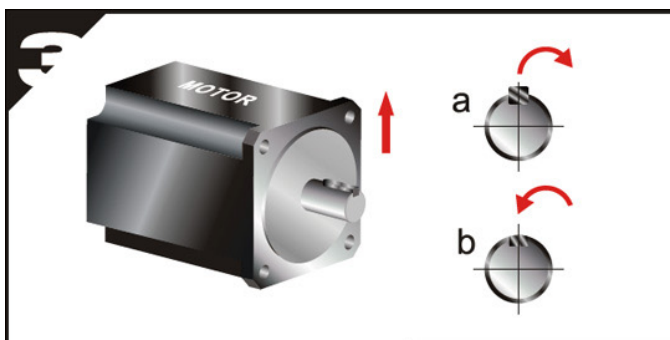

3 a. Remove the motor key
b. Insert balance key if necessary

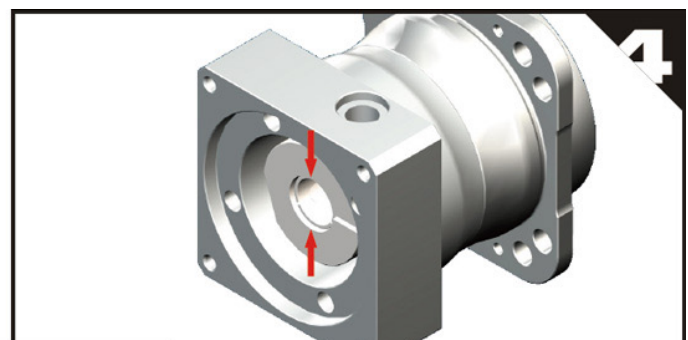

4 Check motor shaft size and insert bushing if necessary

Correct Installation

When installing on flatted shafts, be sure to align the collet gap over the flat and the set collar bolt perpendicular to the flat

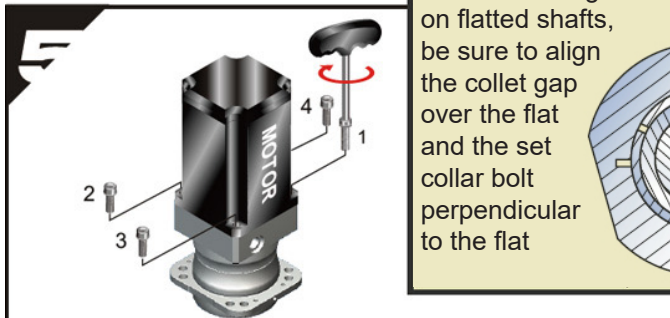
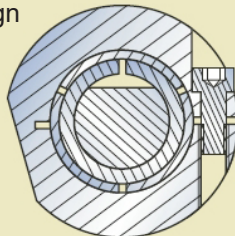

5 Set at vertical position, tighten the mounting bolts (including washer) in 1 - 4 order with wrench to 5% specified torque (see table 1)



6 Tighten the set collar bolt with torque wrench to specified torque (see table 2)



7 Tighten the mounting bolts in 1 - 4 order with torque wrench to specified torque (see table 1)



8 Tighten back the screw plug

Table 1 Tightening torque recommended for motor mounting bolt

Bolt size	Width across flat	Strength 8.8 Tightening torque		Strength 10.9 Tightening torque		Strength 12.9 Tightening torque	
	[mm]	[Nm]	[In-lbs]	[Nm]	[In-lbs]	[Nm]	[In-lbs]
M3 x 0.5P	2.5	1.3	12	1.8	16	2.1	19
M4 x 0.7P	3	3	27	4.1	37	4.9	44
M5 x 0.8P	4	6.1	55	8.2	73	9.8	87
M6 x 1P	5	11	98	14	124	17	151
M8 x 1.25P	6	25	222	34	302	41	364
M10 x 1.5P	8	49	434	67	594	80	709
M12 x 1.75P	10	85	753	116	1028	139	1232
M14 x 2P	12	137	1214	186	1648	223	1976
M16 x 2P	14	210	1860	286	2534	343	3038

Table 2 Tightening torque recommended for set collar bolt

Gearbox size		8	11	14	19	24	28	32	35	38	42	48	55	60
MGO115	1-Stage	-	-	M6	M6	M10	-	-	-	-	-	-	-	-
	2-Stage	-	M5	M5	M6	-	-	-	-	-	-	-	-	-
MGO140	1-Stage	-	-	-	M8	M10	M10	M10	M12	M12	-	-	-	-
	2-Stage	-	-	M6	M6	M10	-	-	-	-	-	-	-	-
MGO170	1-Stage	-	-	-	-	M10	M10	M10	M12	M12	M12	M16	-	-
	2-Stage	-	-	-	M8	M10	M10	M10	M12	M12	-	-	-	-
MGO240	1-Stage	-	-	-	-	-	-	M10	M12	M12	M12	M16	-	-
	2-Stage	-	-	-	-	M10	M10	M10	M12	M12	M12	M16	-	-
MGO285	1-Stage	-	-	-	-	-	-	-	M12	M12	M12	M16	M16	-
	2-Stage	-	-	-	-	-	-	M10	M12	M12	M12	M16	-	-
MGO320	1-Stage	-	-	-	-	-	-	-	M12	M12	M12	M16	M16	M16
	2-Stage	-	-	-	-	-	-	-	M12	M12	M12	M16	-	-

Bolt size	[mm]	M5 x 0.8P	M6 x 1P	M8 x 1.25P	M10 x 1.5P	M12 x 1.75P	M16 x 2P
Width across flats	[mm]	4	5	6	8	10	14
Tightening Torque	[Nm]	9.8	17	41	80	139	343
	[In-lbs]	87	151	364	709	1232	3038

Note: Bolts can be tightened up to 20% higher for increased tightening torques

Apex Dynamics BV
Churchillaan 101
5705 BK Helmond
Nederland

Netherlands
Tel. : +31 (0)492 509 995
E-mail: sales@apexdyna.nl
Web : www.apexdyna.nl

Belgium
Tel. : +32 (0)3 808 15 62
E-mail: sales@apexdyna.be
Web : www.apexdyna.be